

## *Advanced Genetics*

### Gene Mapping

1. The recessive gene *s* produces shrunken endosperm in corn kernels and its dominant allele *S* produces full, plump kernels. The recessive gene *c* produces colorless endosperm and its dominant allele *C* produces colored endosperm. Two homozygous plants are crossed, producing an  $F_1$  which are all phenotypically plump and colored. The  $F_1$  plants are test-crossed with homozygous recessive plants and produce the following progeny:
 

shrunken, colorless	4035
plump, colored	4032
shrunken, colored	149
plump, colorless	152

  - a) What were the phenotypes and genotypes of the original parents?
  - b) How are the genes linked in the  $F_1$ ?
  - c) Calculate the map distance between the two gene loci.
  
2. In corn, the gene *R* for red color is dominant over the gene *r* for green color. The gene *N* for normal seeds is dominant over the gene *n* for tassel seed. A fully heterozygous red plant with normal seeds was crossed with a green plant with tassel seeds, and the following ratios were obtained in the offspring:
 

124 red, normal
77 red, tassel
126 green, tassel
72 green, normal.

 Does this indicate linkage? If so, what is the map distance between the two loci?
  
3. Suppose genes *A* and *B* are 14.5 map units apart. Another gene, *C*, linked to these, is found to cross with gene *B*, 7 percent of the time. Are these data sufficient to determine the exact order of the three genes? If not, what other information is needed to order the genes?
  
4. The cross-over percentage between linked genes *J* and *M* is 20%, *J* and *L* 35%, *J* and *N* 70%, *L* and *K* 15%. *M* and *N* 50%, *M* and *K* 30%, and *M* and *L* 15%. Thus, the sequence of genes on this chromosome is
 

---
  
5. One of your unicorns gives birth after you and she toured the Ukraine. The  does not look like its parents or your other unicorns. While your animals have a straight horn and a green coat; this one has a twisted horn and a blue coat. You mate "Old Blue" and keep only the blue offspring, after successive generations you have pure-breeding progeny of "Old Blue." Now when you mate animals from your two populations: all the progeny have straight horns and green coats. These hybrid offspring are then crossed to unicorns with twisted horns—blue coats. This cross produces offspring in the following numbers:

horn	coat	number
straight	green	855
twisted	blue	855
twisted	green	95
straight	blue	95

Construct a linkage map for the genes involved in this cross.



- Can you distinguish between two gene loci located on the same chromosome that have 50 percent crossing over and two gene loci each located on different chromosomes? Explain.
- The Rh genotypes for each individual in the pedigree are shown below. Solid symbols represent elliptocytotic individuals. (a) List the E locus genotypes for each individual in the pedigree. (b) List the gametic contribution (for both loci) of the elliptocytotic individuals (of genotype Rr) beside each of their offspring in which it can be detected. (c) How often in part (b) did R segregate with E and r with e? (d) On the basis of random assortment, in how many of the offspring of part (b) would we expect to find R segregating with e or r with E? (e) If these genes assort independently, calculate the probability of R segregating with E and r with e in all 10 cases. (f) Is the solution to part (c) suggestive of linkage between these two loci? (g) Calculate part (e) if the siblings III1 and III2 were identical twins. (h) How are these genes probably linked in II?

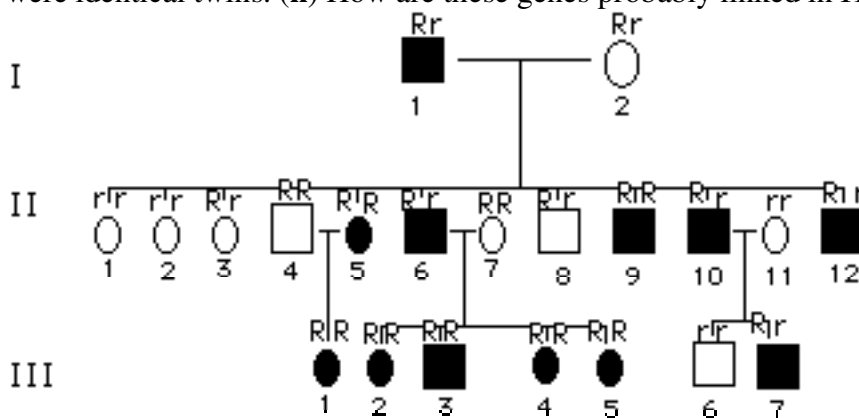

**Sex reversal**

- The developing gonad in young larvae of goldfish is ambisexual and subject to differentiate into either an ovary or a testis, irrespective of its sex genotype, by exogenous exposure to heterotypic sex hormones. The sex genes are not the direct cause of sex differentiation, but act indirectly by producing sex-inducing hormones. Estrogens and androgens are usually considered to be responsible for the expression of secondary sexual characteristics and for the maintenance of sexual capacities. However, in the case of this species, estrogens can also act as ovary-inducing agent and androgens, as testis-inducing agent. (a) If females are heterogametic (ZW) and males are homogametic (ZZ),

predict the offspring expected from a presumptive male (ZZ) converted by estrone treatment into a female and mated to a normal male (ZZ). (b) If males are heterogametic (XY) and females are homogametic (XX), predict the zygotic expectations from a presumptive male induced to become a female and mated to a normal male. (c) This species produces viable offspring in the ratios predicted in part (b). What is so unusual about this finding? (d) As an additional proof that males are heterogametic in this species, an induced-male of a genotypic female is mated to a normal female. What type of progeny is expected? (e) An induced-(XY) female was mated to a normal male and produced 7 sons (1 died). Each of the 6 viable sons was crossed with normal females (XX). Five of the six matings produced both male and female progeny. The sixth mating, however, produced 198 offspring, all males. The male parent lived 8 years. What does this indicate regarding the frequency of such males?

### Haplodiploidy

9. Males bees are known to develop parthenogenically from unfertilized eggs and are therefore haploid. Females (both workers and queens) originate from fertilized (diploid) eggs. Sex chromosomes are not involved in this mechanism of sex determination which is characteristic of the insect order Hymenoptera. The quantity and quality of food available to the diploid larvae determine whether that female will become a sterile worker or a fertile queen. Thus environment here determines sterility or fertility but does not alter the genetically determined sex. The sex ratio of the offspring is under the control of the queen. Most of the eggs laid in the hive will be fertilized and develop into worker females. Those eggs which the queen chooses not to fertilize (from her store of sperm in the seminal receptacle) will develop into fertile haploid males. Queen bees usually mate only once during their lifetime. If the diploid number of the honey bee is 16, (a) how many chromosomes will be found in the somatic cells of the drone, (b) how many tetrads\* will be seen during the process of gametogenesis in the male, (c) how many tetrads\* will be seen during the process of gametogenesis in the female?

### Genic balance

Sex chromosomes in *Drosophila* are similar to those in humans in that both females have XX genotypes and males, XY. At least one X chromosome is essential for survival. The presence of the Y chromosome in *Drosophila*, though it is essential for male fertility, apparently has nothing to do with the determination of sex. Instead, the factors for maleness residing in all of the autosomes are “weighed” against the factors for femaleness residing on the X chromosome(s). If each haploid set of autosomes carries factors with a male-determining value equal to one, then each X chromosome carries factors with a female-determining value of 1.5. Let  $\underline{A}$  represent a haploid set of autosomes. In a normal male (AAXY), the male:female determinants are in the ratio 2:1.5 and therefore the balance is in favor of maleness. A normal female (AAXX) has a male: female ratio of 2:3 and therefore the balance is in favor of femaleness. Several abnormal combinations of chromosomes have confirmed this hypothesis. For example, an individual with three sets of autosomes and two X chromosomes has a ratio of 3:3 which makes its

---

\*Recall that tetrad refers to synapsed homologues in prophase I.

genetic sex neutral, and indeed phenotypically it appears as a sterile intersex.

10. In *Drosophila*, the ratio between the number of X chromosomes and the number of sets of autosomes ( $\bar{A}$ ) is called the "sex index." Diploid females have a sex index (ratio  $\bar{X}/\bar{A}$ ) =  $2/2 = 1.0$  Diploid males have a sex index of  $1/2 = 0.5$ . Sex index values between 0.5 and 1.0 give rise to intersexes. Values over 1.0 or under 0.5 produce weak and inviable flies called superfemales and supermales, respectively. Calculate the sex index and the sex phenotype in the following individuals: (a) AAX, (b) AAXXY, (c) AAAXX, (d) AAXX, (e) AAXXX, (f) AAAXXX, (g) AAY.

### Holandric

11. It was once believed that an holandric gene in humans causes long hair to grow on the external ears<sup>1</sup>. If that was true, if men with hairy ears marry normal women:
- what percentage of their sons would be expected to have hairy ears,
  - what proportion of the daughters is expected to show the trait,
  - what ratio of hairy eared:normal children is expected?

### Sex-influenced

12. The fourth (ring) finger of humans may be longer or shorter than the second (index) finger. The short index finger is produced by an autosomal allele that is dominant in men and recessive in women. What kinds of children and in what proportions would the following marriage be likely to produce: heterozygous long-fingered woman  $\times$  homozygous short-fingered man. Give gender and finger length of children.



---

<sup>1</sup> Dronamraju, K. R. "Y-linkage in man." *Nature* 201:424-425, 1964.